



30RY 017-080 "B"

Ductable Liquid Chillers with Integrated Hydronic Module

Nominal cooling capacity 18-79 kW

50 Hz

PRO-DIALOG *PLUS*

AQUASNAP

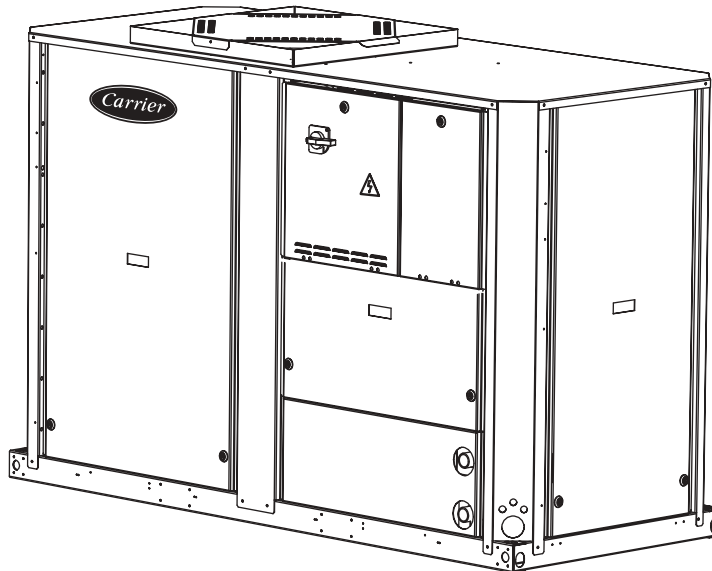

Carrier is participating in the Eurovent Certification Programme. Products are as listed in the Eurovent Directory of Certified Products.

For the operation of the control please refer to the Pro-Dialog *PLUS* Control manual for the 30RA/RH - 30RY/RH "B" series



Installation, operation and maintenance instructions



Quality Management System Approval

3 - DIMENSIONS/CLEARANCES

30RY 017-033

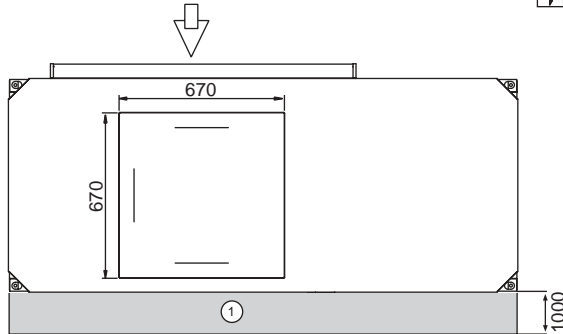
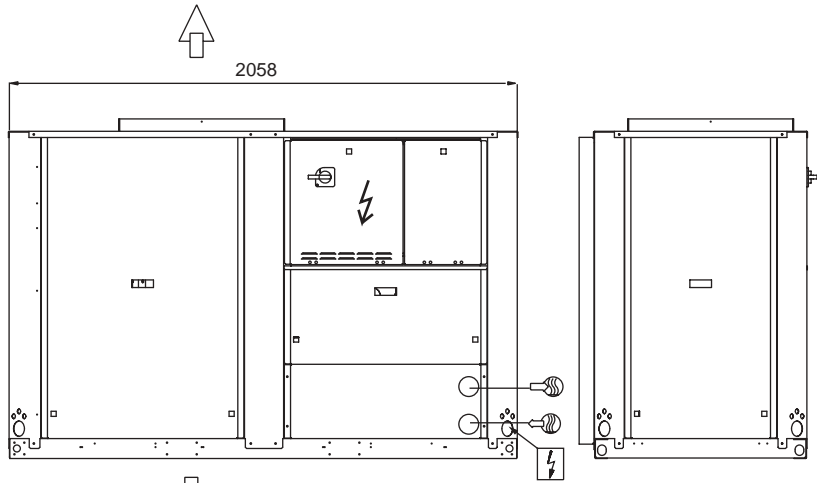
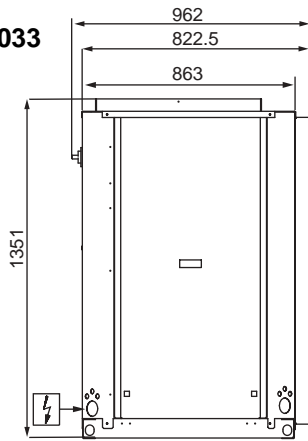

30RY 040-080

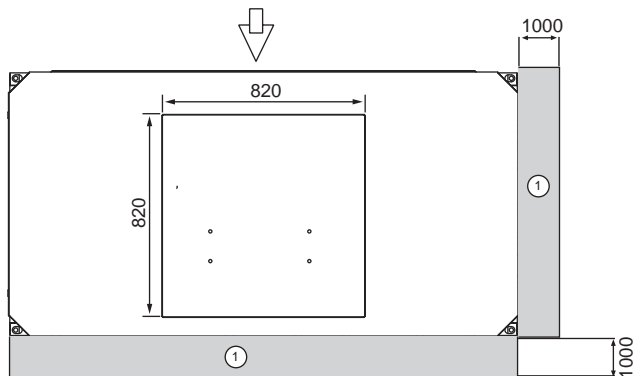
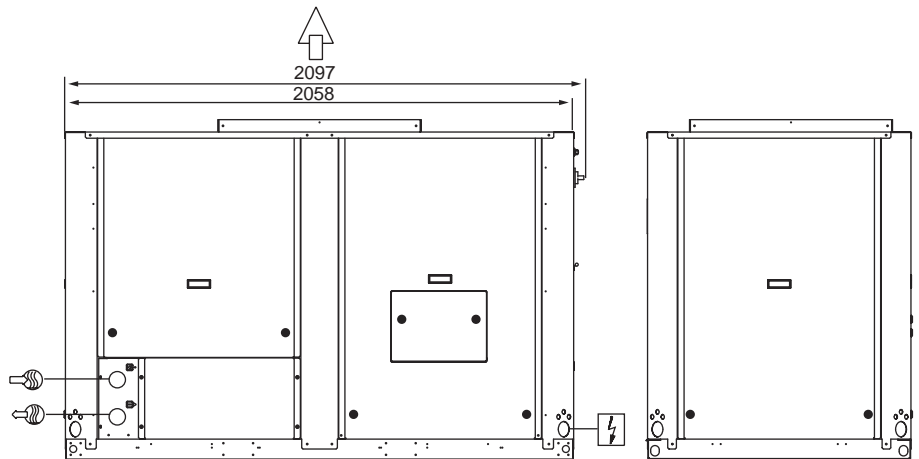
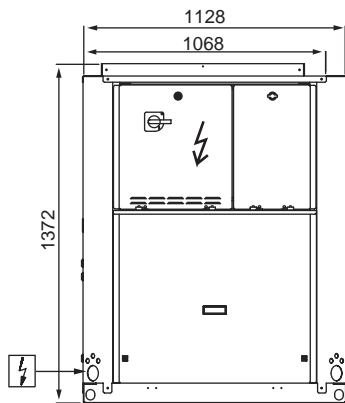

Legend:

All dimensions are given in mm

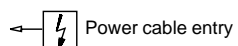
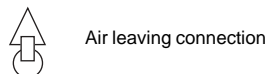
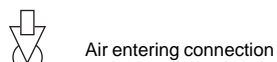
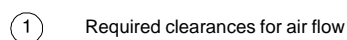
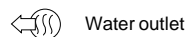

NOTE:

- A** *Non-certified drawings. Refer to the certified dimensional drawings supplied with the unit or available on request, when designing an installation.*
- For the location of fixing points, weight distribution and coordinates of the centre of gravity refer to the certified dimensional drawings.*
- B** *Install a condensate collection channel around the unit, or install the accessory condensate recovery pan.*
- C** *The unit must be installed level in both axes (less than 2 mm tolerance per metre).*

4 - PHYSICAL DATA

30RY		017	021	026	033	040	050	060	070	080	
Nominal cooling capacity*	kW	18.6	23.1	25.8	31.7	39.4	50.0	58.0	67.0	79.0	
Operating weight	kg										
with hydronic module, single pump		386	416	436	451	510	572	587	638	675	
with hydronic module, dual pump		-	-	-	-	590	652	667	718	752	
without hydronic module		361	391	411	426	486	548	563	614	649	
Refrigerant charge R-407C	kg	6.6	6.3	7.45	7.85	9.75	11.1	11.8	13.3	17.0	
Compressors		Hermetic scroll compressors, 48.3 r/s									
Quantity		1	1	1	1	1	2	2	2	2	
No. of capacity steps		1	1	1	1	1	2	2	2	2	
Minimum capacity	%	100	100	100	100	100	46	42	50	50	
Control type		PRO-DIALOG Plus									
Condenser		Grooved copper tubes, aluminium fins									
Fan		Axial with available pressure									
Quantity		1	1	1	1	1	1	1	1	1	
Available static pressure	Pa	100	100	100	100	150	150	150	150	150	
Total air flow (high speed)	l/s	1940	1940	1940	2500	3890	3890	4720	5830	5830	
Speed (high/low speed)	r/s	24/12	24/12	24/12	24/12	24/12	24/12	24/12	24/12	24/12	
Evaporator		Direct-expansion welded plate heat exchanger									
Water volume	l	1.6	2.0	2.3	3.0	3.6	4.6	5.9	6.5	7.6	
Max. water-side operating pressure	kPa										
Option without hydronic module		1000	1000	1000	1000	1000	1000	1000	1000	1000	
Unit with hydronic module		250	250	250	250	300	300	300	300	300	
Hydronic module		Single multicell pump, 48.3 r/s				Single composite monocell pump, 48.3 r/s					
Pump (centrifugal)		1	1	1	1	1	1	1	1	1	
Expansion tank volume	l	8	8	8	8	12	12	12	12	12	
Expansion tank pressure**	kPa	50	50	50	50	100	100	100	100	100	
Water connections		Threaded male gas connections				Victaulic					
(with and without hydronic module)		(sleeves for welding or screw connections supplied)									
Diameter	in	1-1/4	1-1/4	1-1/4	1-1/4	2	2	2	2	2	
Outside tube diameter	in	1-1/4	1-1/4	1-1/4	1-1/4	2	2	2	2	2	
	mm	42.4	42.4	42.4	42.4	60.3	60.3	60.3	60.3	60.3	

* Nominal conditions: evaporator entering/leaving temperature 12°C/7°C, outdoor air temperature 35°C.

** When delivered, the pre-inflation of the tank keeps the plated membrane in the upper part of the tank. To permit changing the water volume, change the inflation pressure to a pressure that is close to the static head of the system (see below), fill the system with water (purging the air) to a pressure value that is 10 to 20 kPa higher than the pressure in the tank.

Static head, m/Pressure, bar/Pressure, kPa

5 - 0,5 - 50 / 10 - 1 - 100 / 15 - 1,5 - 150 / 20 - 2 - 200 / 25 - 2,5 - 250

5 - ELECTRICAL DATA

30RY (without hydronic module)		017	021	026	033	040	050	060	070	080
Power circuit										
Nominal power supply	V-ph-Hz	400-3-50								
Voltage range	V	360-440								
Control circuit supply		The control circuit is supplied via the unit-mounted transformer								
Maximum unit power input*	kW	9.8	12.1	13.8	18.0	21.0	25.3	32.3	38.2	42.9
Nominal unit current draw**	A	13.1	16.2	18.6	23.3	28.8	35.6	45.7	52.1	59.4
Maximum unit current draw at 360 V***	A	17.0	21.3	24.5	31.2	37.8	46.5	59.5	67.8	77.5
Maximum unit current draw at 400 V****	A	15.5	19.3	22.2	28.3	34.5	42.3	54.3	62.1	70.7
Maximum start-up current										
Standard unit†	A	87.8	131.8	131.8	147.4	159.3	151.8	173.5	181.2	195.5
With electronic starter option‡	A	-	-	-	-	97.3	99.8	115.5	123.2	133.5
Short-circuit stability and protection		See table on the next page								

* Power input of the compressor(s) + fan at maximum unit operating conditions: entering/leaving water temperature = 15°C/10°C, maximum condensing temperature of 67.8°C and 400 V nominal voltage (values given on the unit name plate).

** Nominal unit current draw at the following conditions: evaporator entering/leaving water temperature 12°C/7°C, outdoor air temperature 35°C. The current values are given at 400 V nominal voltage

*** Maximum unit operating current at maximum unit power input and 360 V nominal voltage.

**** Maximum unit operating current at maximum unit power input and 400 V nominal voltage (values given on the unit name plate).

† Maximum instantaneous starting current at 400 V nominal voltage and with compressor in across-the-line-start (maximum operating current of the smallest compressor(s) + fan current + locked rotor current of the largest compressor).

‡ Maximum instantaneous starting current at 400 V nominal voltage and with compressor with electronic starter (maximum operating current of the smallest compressor(s) + fan current + reduced start-up current of the largest compressor).

Hydronic module		017	021	026	033	040	050	060	070	080
Single pump										
Shaft power	kW	0.75	0.75	0.75	0.75	0.75	0.75	0.75	0.75	1.1
Power input*	kW	0.75	0.75	0.75	0.75	1.1	1.1	1.1	1.1	1.4
Maximum current draw at 400 V**	A	2.0	2.0	2.0	2.0	2.1	2.1	2.1	2.1	3.1
Dual pump										
Shaft power	kW	-	-	-	-	2.2	2.2	2.2	2.2	2.2
Power input*	kW	-	-	-	-	2.7	2.7	2.7	2.7	2.7
Maximum current draw at 400 V**	A	-	-	-	-	4.7	4.7	4.7	4.7	4.7

Note: The water pump power input values are given for guidance only.

* To obtain the maximum power input for a unit with hydronic module add the maximum unit power input from the top table to the pump power input (*) from the table above.

** To obtain the maximum unit operating current draw for a unit with hydronic module add the maximum unit current draw from the top table to the pump current draw from the table above.

Compressor usage and electrical data

Reference code	COMPRESSOR				30RY									
	I Nom	I Max	LRA*	Circuit	017	021	026	033	040	050	060	070	080	
DQ 12 CA 001EE	14.0	19.1	130	A		A1				A1				
DQ 12 CA 002EE	16.2	22.1	130	A			A1			A2	A1			
DQ 12 CA 025EE	14.8	20.3	86	A	A1									
DQ 12 CA 031EE	21.9	28.3	145	A				A1			A2	A1+A2		
DQ 12 CA 036EE	24.5	32.9	155	A					A1				A1+A2	

Legend:

I Nom Nominal current draw at Eurovent conditions (see definition of conditions under nominal unit current draw), A
I Max Maximum operating current at 360 V, A
LRA Locked rotor current, A

* With option 25 (electronic starter) the LRA value is reduced by 40%; the maximum start-up time per compressor is <0.8 seconds.

Short-circuit stability and protection

30RY	Short-term short-circuit stability (1s) Without fuse rms value/peak kA*	With fuse rms value kA**	Other fuses rms value kA***	Other protection type I ² t (A ² s)/peak limit kA****
017-033	5/7.5	40A gL:100	50A gL:100 63A gL:100 80A gL:50	8700/9
040-080	5/7.5	80A gL:50	100A gL:30 125A gL:25 160A gL:6	19200/12

* This value corresponds to the switch/disconnect capacity, to the power distribution bus bar system capacity (if used) and to the protection circuit capacity in the standard unit.

** If the available short-circuit current is higher, the unit can be protected by the fuse shown for the specific level.
The fuses (not supplied for Carrier units) are as recommended, to be installed upstream of the unit. A fused disconnect switch, equipped with fuses, can be installed in place of the standard unit switch. This should be done on site; please contact the local service department or a qualified electrician. Alternatively please order the special version from the factory by contacting your local Carrier dealer.

List of recommended components with Siemens reference details:

30RY	Fused disconnect	Contact protection	Control handle	NH Fuses	New protection level with fused disconnect switch, rms value, kA**
017-033	45 A: 3KL7112-3AA00	3KX71-32-1AA00	Use from disconnect switch	40 A 00gL: 3NA3 817 (3 off)	100
040-080	80 A: 3KL7114-3AA00	3KX71-32-1AA00	of the standard unit	80 A 00gL: 3NA3 824 (3 off)	100

*** Shows the new protection values with higher-capacity fuses than those specified in the previous column. If such fuses are part of the electrical installation upstream of the unit, this is sufficient as anti-short circuit protection to the specified level, without additional protection.

**** If a protection device, other than the recommended fuses above, is used for the installation to ensure that no additional protection is required, the protection device must have the specified thermal limit (I²t) and limit effect characteristics for the short-circuit current. If the protection device does not have the specified characteristics, one of the specified protection fuses from the previous columns must be installed.

Electrical data notes for 30RY units:

- 30RY 017-080 units have a single power connection point.
- The control box includes the following standard features:
 - Starter and motor protection devices for each compressor, fan, optional pump
 - Control devices
- **Field connections:**
All connections to the system and the electrical installations must be in full accordance with all applicable codes.
- The Carrier 30RY 017-080 units are designed and built to ensure conformance with local codes. The recommendations of European standard EN 60204-1 (machine safety - electrical machine components - part 1: general regulations - corresponds to IEC 60204-1) are specifically taken into account when designing the electrical equipment.

IMPORTANT:

- Generally the recommendations of IEC 60364 are accepted as compliance with the requirements of the installation directives. Conformance with EN 60204-1 is the best means of ensuring compliance with the Machines Directive § 1.5.1.
- Annex B of EN 60204-1 describes the electrical characteristics used for the operation of the machines.

1. The operating environment for the 30RY units is specified below:

a. 30RY 017-080 – Indoor installation

Environment* - Environment as classified in IEC 60364 § 3:

- ambient temperature range: +5°C to +40°C, class AA4
- humidity range (non-condensing)*:
50% relative humidity at 40°C
90% relative humidity at 20°C
- altitude: ≤ 2000 m
- indoor installation*
- presence of water, class AD2* (possibility of water droplets)
- presence of hard solids, class AE2* (no significant dust present)
- presence of corrosive and polluting substances, class AF1 (negligible)
- vibration and shock, class AG2, AH2

Competence of personnel, class BA4* (trained personnel - IEC 60364)

b. 30RY 040-080 – outdoor installation

Environment** - Environment as classified in EN 60721 (corresponds to IEC 60721):

- outdoor installation**
- ambient temperature range: -10°C to +46°C, class 4K3**
- altitude: ≤ 2000 m
- presence of hard solids: class 4S2** (no significant dust present)
- presence of corrosive and polluting substances, class 4C2 (negligible)
- vibration and shock, class 4M2

Competence of personnel, class BA4** (trained personnel - IEC 60364)

- Power supply frequency variation: ± 2 Hz.
- The neutral (N) conductor must not be connected directly to the unit (if necessary use a transformer).
- Overcurrent protection of the power supply conductors is not provided with the unit.
- The factory-installed disconnect switch(es)/circuit breaker(s) is (are) of a type suitable for power interruption in accordance with EN 60947.
- The units are designed for connection to TN networks (IEC 60364). For IT networks the earth connection must not be at the network earth. Provide a local earth, consult competent local organisations to complete the electrical installation.

NOTE: If particular aspects of an actual installation do not conform to the conditions described above, or if there are other conditions which should be considered, always contact your local Carrier representative.

* The protection level required to conform to this class is IP21B (according to reference document IEC 60529). All 30RY 017-080 units are protected to IP23C and fulfil this protection condition.

** The required protection level for this class is IP43BW (according to reference document IEC 60529). All 30RY 040-080 units are protected to IP45CW and fulfil this protection condition.

6 - APPLICATION DATA

6.1 - Unit operating range

Evaporator	Minimum °C	Maximum °C
Water entering temp. (at start-up)	7.8 *	30
Water leaving temp. (in operation)	5 **	10
Water entering temp. (at shut down)	-	50
Condenser		
Entering air temp.	-10***	46***

Do not exceed the maximum operating temperature.

* For a system requiring operation below 7,8°C, contact Carrier SA.

** For a system requiring operation below 5°C, anti-freeze must be added to the unit.

*** Maximum outside temperature: For transport and storage of the 30RY units the minimum and maximum allowable temperatures are -20°C and +55°C. It is recommended that these temperatures are used for transport by container.

6.2 - Evaporator water flow rates

30RY	Evaporator water flow			
	Min. flow rate	Max. flow rate*		Max. flow rate**
	l/s	Single pump l/s	Dual pump l/s	l/s
017	0.58	1.7	0	1.7
021	0.70	1.8	0	1.9
026	0.81	1.9	0	2.2
033	1.10	2.0	0	3.0
040	1.20	3.5	4.4	3.7
050	1.19	4.0	5.2	4.6
060	1.46	4.4	6.0	5.8
070	1.66	4.6	6.4	6.4
080	1.92	5.5	6.8	7.3

* Maximum flow rate at an available pressure of 50 kPa (unit with hydronic module).

** Maximum flow rate at a pressure drop of 100 kPa in the plate heat exchanger (unit without hydronic module).

6.3 - Minimum water flow rate

If the installation flow rate is below the minimum flow rate, recirculation of the evaporator water flow may take place, leading to the risk of excessive fouling.

6.4 - Maximum evaporator water flow rate

This is limited by the permitted evaporator pressure drop. Also, a minimum evaporator ΔT of 2.8 K must be guaranteed, which corresponds to a water flow rate of 0.9 l/s per kW.

6.5 - Water loop volume

6.5.1 - Minimum water loop volume

The minimum water loop volume, in litres, is given by the following formula:

Volume = CAP (kW) x N* = litres, where CAP is the nominal cooling capacity at nominal operating conditions.

Application	N*
Air conditioning	
30RY 017-040	3.5
30RY 050-240	2.5
Industrial process cooling	
30RY 017-080	(See note)

NOTE: For industrial process cooling applications, where high stability of the water temperature levels must be achieved, the values above must be increased.

This volume is required to obtain temperature stability and precision.

To achieve this volume, it may be necessary to add a storage tank to the circuit. This tank should be equipped with baffles to allow mixing of the fluid (water or brine). Please refer to the examples below.

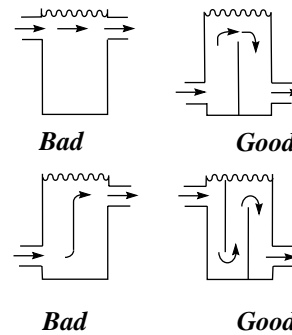

6.5.2 - Maximum water loop volume

Units with hydronic module incorporate an expansion tank that limits the water loop volume. The table below gives the maximum loop volume for pure water or ethylene glycol with various concentrations.

	30RY 017-033 (in litres)	30RY 040-080 (in litres)
Pure water	400	600
Ethylene glycol 10%	300	450
Ethylene glycol 20%	250	400
Ethylene glycol 35%	200	300

EG: Ethylene glycol

6.6 - 30RY unit operating range at full and part load

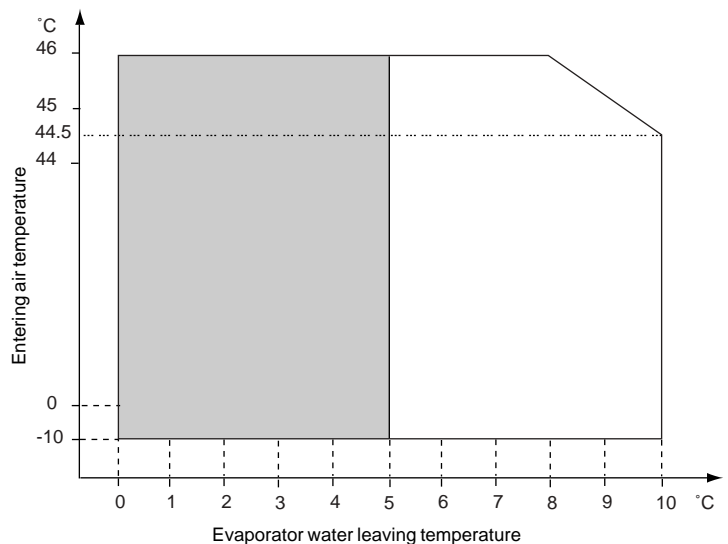

Notes

1 Evaporator $\Delta T = 5$ K

2 The evaporator and the hydronic circuit pump are frost protected down to -20°C.

Operating range with required anti-freeze solution and special Pro-Dialog control configuration

6.7 - Pressure drop in the plate heat exchangers

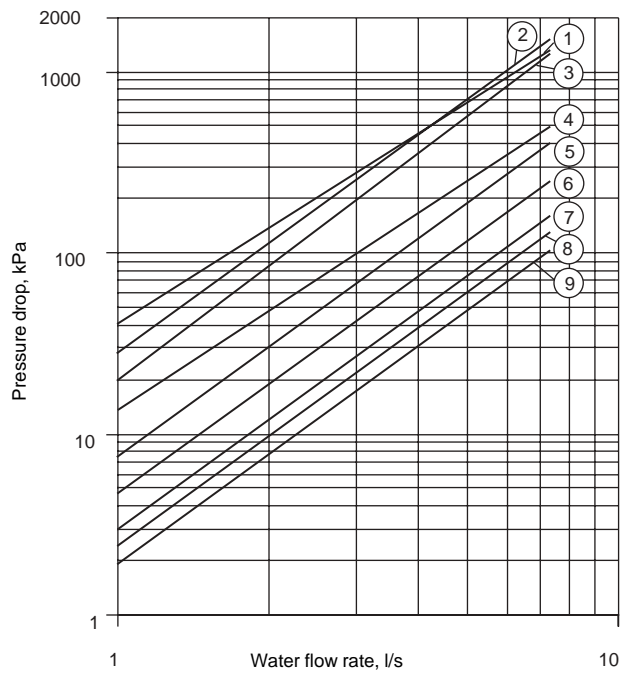

Legend

- 1 30RY 017
- 2 30RY 021
- 3 30RY 026
- 4 30RY 033
- 5 30RY 040
- 6 30RY 050
- 7 30RY 060
- 8 30RY 070
- 9 30RY 080

7 - ELECTRICAL CONNECTION

30RY 017-033

Control box

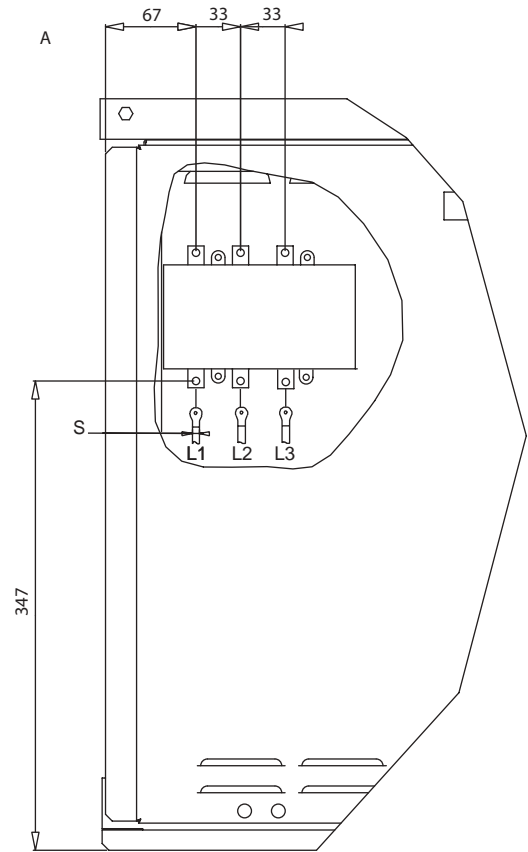
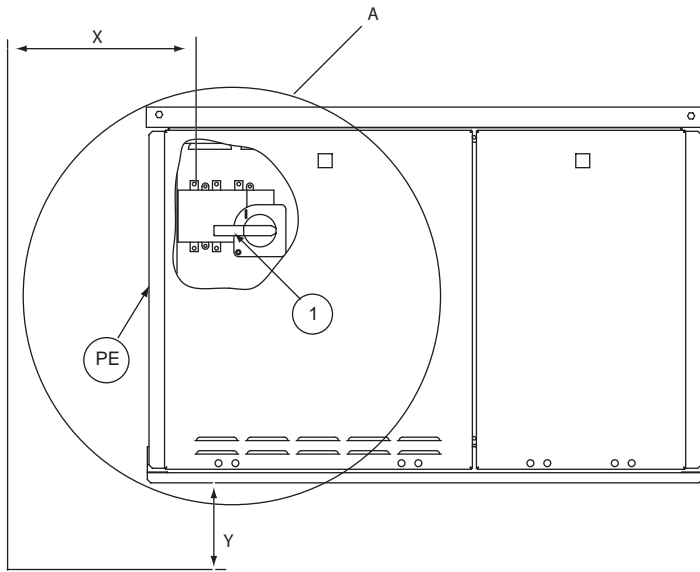

30RY 040-080

Control box

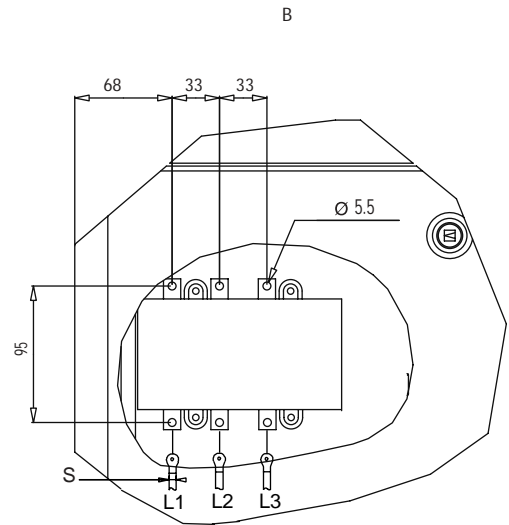
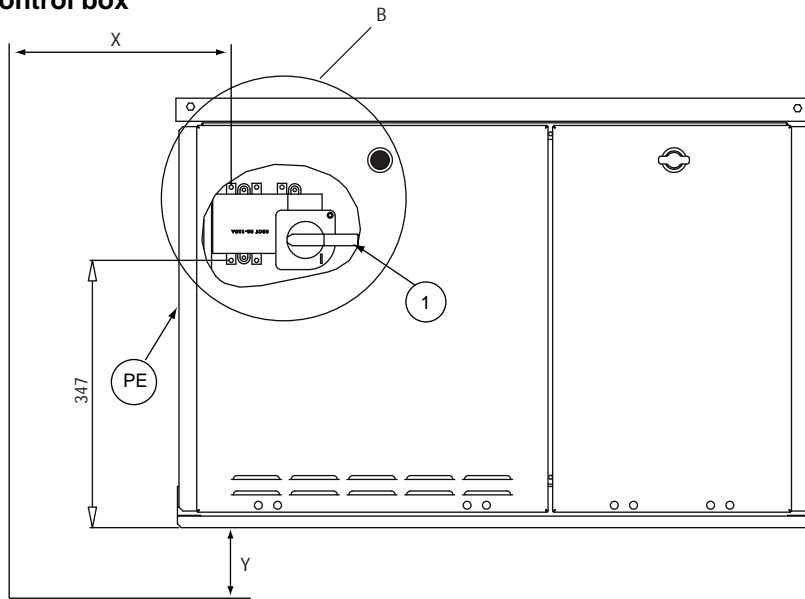

Legend

- 1 Main disconnect switch
- PE Earth connection
- S Power supply cable section (see table "Recommended wire sections").
For copper cables use electrolytic copper (AMP type) cable stiffeners with 6 mm terminal for sizes 017 to 080.

NOTES: The 30RY units have only one power connection point located at the main disconnect switch.

Before connecting electric power cables, it is imperative to check the correct order of the 3 phases (L1 - L2 - L3).

Non-certified drawings. Refer to the certified drawings supplied with the unit or available on request.

30RY	X (mm)	Y (mm)
017-033	1180	761
040-080	190	762

7.1 - Power supply

The power supply must conform to the specification on the chiller name plate. The supply voltage must be within the range specified in the electrical data table.

For connections refer to the wiring diagrams.

WARNING: Operation of the chiller with an improper supply voltage or excessive phase imbalance constitutes abuse which will invalidate the Carrier warranty. If the phase imbalance exceeds 2% for voltage, or 10% for current, contact your local electricity supply source at once and ensure that the chiller is not switched on until corrective measures have been taken.

7.2 - Voltage phase imbalance (%)

$$\frac{100 \times \text{max. deviation from average voltage}}{\text{Average voltage}}$$

Example:

On a 400 V - 3 ph - 50 Hz supply, the individual phase voltages were measured to be:

$$AB = 406 \text{ V} ; BC = 399 ; AC = 394 \text{ V}$$

$$\begin{aligned} \text{Average voltage} &= (406 + 399 + 394)/3 = 1199/3 \\ &= 399.7 \text{ say } 400 \text{ V} \end{aligned}$$

Calculate the maximum deviation from the 400 V average:

$$(AB) = 406 - 400 = 6$$

$$(BC) = 400 - 399 = 1$$

$$(CA) = 400 - 394 = 6$$

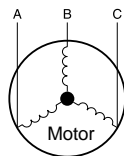

The maximum deviation from the average is 6 V. The greatest percentage deviation is: $100 \times 6/400 = 1.5 \%$

This is less than the permissible 2% and is therefore acceptable.

8 - RECOMMENDED WIRE SECTIONS

Wire sizing is the responsibility of the installer, and depends on the characteristics and regulations applicable to each installation site. The following is only to be used as a guideline, and does not make Carrier in any way liable. After wire sizing has been completed, using the certified dimensional drawing, the installer must ensure easy connection and define any modifications necessary on site. The connections provided as standard for the field-supplied power entry cables to the general disconnect/isolator switch are designed for the number and type of wires, listed in the table below.

The calculations are based on the maximum machine current (see electrical data tables) and the standard installation practises, in accordance with IEC 60364, table 52C.

- For 30RY units, installed outside, the following standard installation practises have been maintained:
No.17: suspended aerial lines, and No. 61: buried conduit with a derating coefficient of 20.

The calculation is based on PVC or XLPE insulated cables with copper core.

A maximum ambient temperature of 46°C has been taken into consideration.

The given wire length limits the voltage drop to < 5% (length L in metres - see table below).

IMPORTANT: Before connection of the main power cables (L1 - L2 - L3) on the terminal block, it is imperative to check the correct order of the 3 phases before proceeding to the connection on the main disconnect/isolator switch.

8.1 - Field control wiring

For the field control wiring of the following elements please refer to the 30RA/RH - RY/RYPH "B" series Pro-Dialog Plus Control manual, and the certified wiring diagram supplied with the unit:

- Unit start/stop
- Heating/cooling selection
- Set-point selection
- Customer interlock - (example: auxiliary contact of the chilled water pump contactor)
- General alarm reporting, circuit A and circuit B

Units	S Min. (mm ²) by phase	Cable type	L (m)	S Max. (mm ²) by phase	Cable type	L (m)
30RY 017	1x 6	XLPE Cu	90	1x 16	PVC Cu	245
30RY 021	1x 6	XLPE Cu	90	1x 16	PVC Cu	245
30RY 026	1x 6	XLPE Cu	90	1x 16	PVC Cu	245
30RY 033	1x 6	XLPE Cu	90	1x 16	PVC Cu	245
30RY 040	1x 6	XLPE Cu	90	1x 16	PVC Cu	245
30RY 050	1x 6	XLPE Cu	80	1x 25	PVC Cu	300
30RY 060	1x 10	XLPE Cu	110	1x 25	PVC Cu	300
30RY 070	1x 10	XLPE Cu	100	1x 35	PVC Cu	310
30RY 080	1x 16	XLPE Cu	125	1x 50	PVC Cu	350

S Power supply cable section (see the diagram in chapter: "Electrical connection")

9.2 - Hydronic connections

The diagram on the next page shows a typical hydronic installation.

When charging the water circuit use air vents to evacuate any residual air pockets.

9.3 - Frost protection

The plate heat exchangers, the piping and the hydronic module pump can be damaged by frost, despite the built-in anti-freeze protection of these units.

The frost protection of plate heat exchanger and all hydronic module components is guaranteed down to -20°C (sizes 040-080 only) by automatically energized heaters and pump cycling.

Never switch off the evaporator and hydronic circuit heaters or the pump, otherwise frost protection cannot be guaranteed.

For this reason the main unit disconnect switch (QS101) as well as the auxiliary protection switch (QF101) for the heaters must always be left closed (for location of QS and QF 101 see wiring diagram).

To ensure frost protection down to -20°C, water circulation in the water circuit must be maintained by periodically switching on the pump. If a shut-off valve is installed, a bypass must be included as shown below.

Winter position

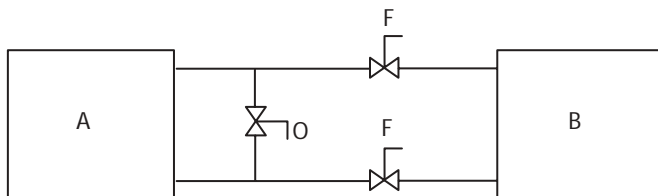

Legend

- A Unit
- B Water network
- C Closed
- O Open

IMPORTANT:

Depending on the atmospheric conditions in your area you must do the following when switching the unit off in winter:

- **Add ethylene glycol with an adequate concentration to protect the installation up to a temperature of 10 K below the lowest temperature likely to occur at the installation site.**
- **If the unit is not used for an extended period, it is recommended to drain it, and as a safety precaution introduce ethylene glycol in the heat exchanger, using the water entering purge valve connection. At the start of the next season, refill the unit with water and add an inhibitor.**
- **For the installation of auxiliary equipment, the installer must comply with basic regulations, especially for minimum and maximum flow rates, which must be between the values listed in the operating limit table (application data).**

- **To prevent corrosion by differential aeration, the complete drained heat transfer circuit must be charged with nitrogen for a period of one month. If the heat transfer fluid does not comply with the Carrier S.A. regulations, the nitrogen charge must be added immediately.**

9.4 - Installation of the accessory condensate recovery pan

Ref. No.: 30RY 900 022 EE -- 30RY 017-033
30RY 900 032 EE -- 30RY 040-080

In heat pump mode it may be necessary to remove the water. Carrier can supply an accessory condensate recovery pan to be positioned under the unit. This pan is connected to the condensate recovery systems via a threaded 1" diameter gas pipe.

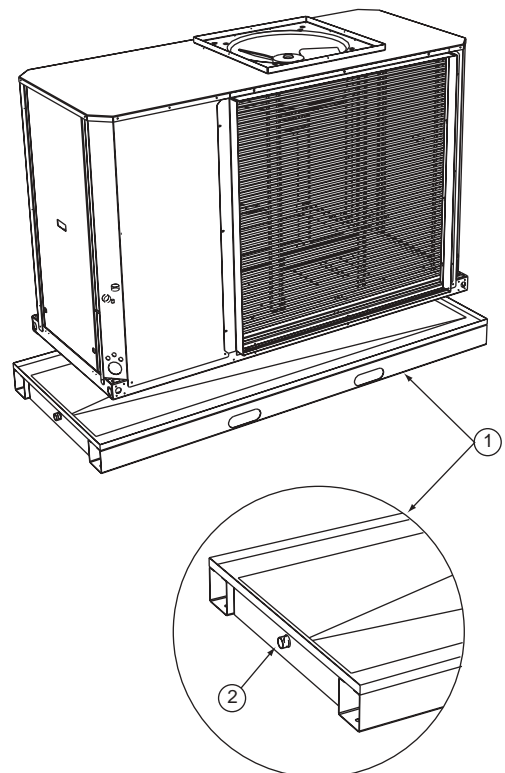

Legend

- 1 Condensate recovery pan
- 2 Connection

10.4 - Available static system pressure

Single pump

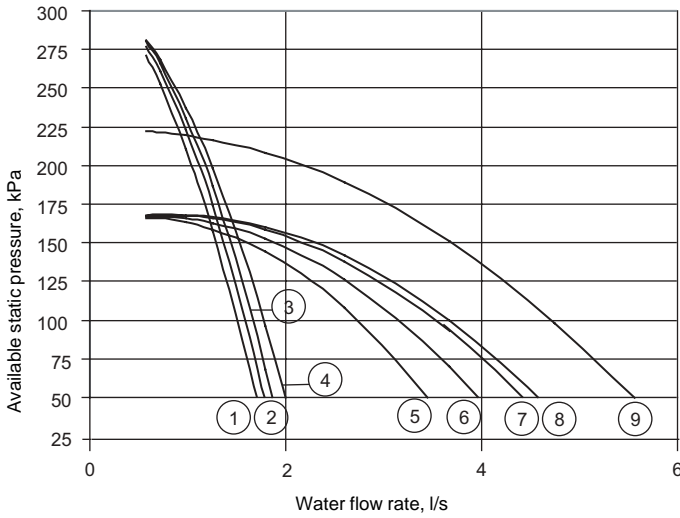

Legend

- 1 30RY 017
- 2 30RY 021
- 3 30RY 026
- 4 30RY 033
- 5 30RY 040
- 6 30RY 050
- 7 30RY 060
- 8 30RY 070
- 9 30RY 080

Dual pump

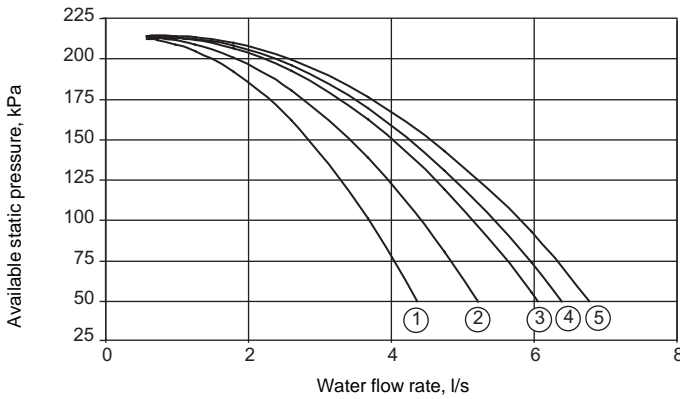

Legend

- 1 30RY 040
- 2 30RY 050
- 3 30RY 060
- 4 30RY 070
- 5 30RY 080

10.5 - Duct connection

The 30RY 017-080 can be installed inside a building and connected to an air ductwork system:

- air heat exchanger side, i.e. at the fresh air inlet side
- fan discharge side, i.e. where the air treated by the heat exchanger is discharged.

Installation in a room is thus possible without disturbing the room temperature.

10.5.1 - Air return without accessory filter

The units are supplied with a collar that permits connection of a return air duct.

Provide a removable window on the return air duct to permit maintenance of the air temperature sensor.

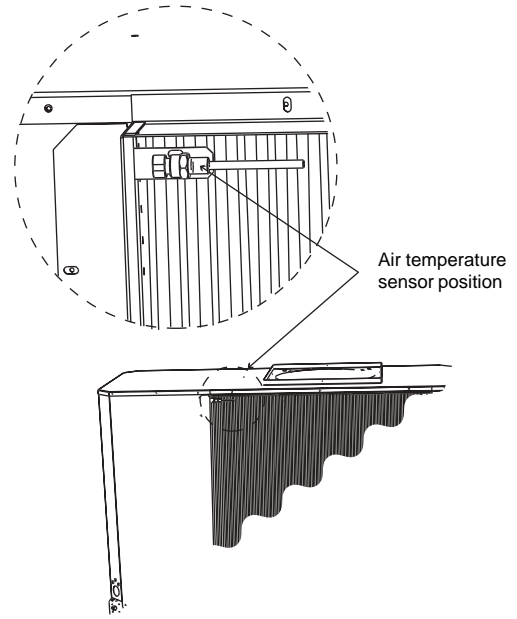

10.5.2 - Air return with accessory filter

The suction side connection collar must first be removed.

Installation of the accessory on the unit can be done as follows:

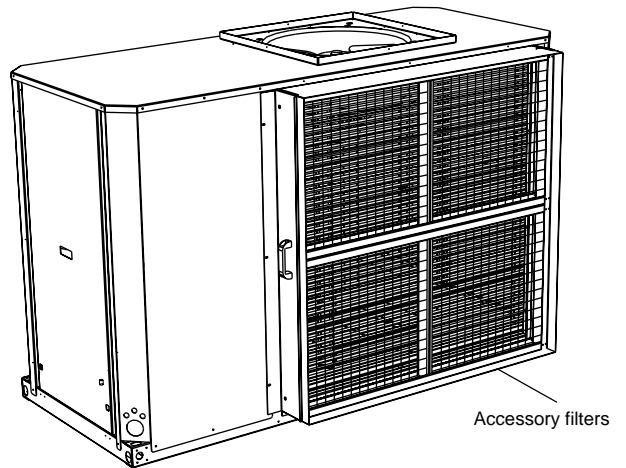

Accessory reference number:

30RY-017-033: 30RY-900—002—EE—

30RY-040-080: 30RY-900—012—EE—

Replacement filter reference number:

—KH—12AE-005—EE—

30RY-017-033: quantity: 4

30RY-040-080: quantity: 6

The connection of the return air duct is now very easy, directly on the air filter accessory.

Filter access for maintenance is ensured by removing the two Metric screws on the unit side (rear view of the unit).

The cover panel, supplied with a handle, can now be removed.

The filters are attached to each other with a bracket that permits sliding them into the frames.

10.5.3 - Fan discharge

A square flange is supplied mounted on the unit. An available standard round flange can easily be installed at the fan discharge, if the installer prefers the use of a round connection duct.

The unit is supplied with a cover panel on the discharge side. This panel has to be removed before connection to the duct system.

30RY-017-033: standard 560 mm diameter fan

30RY-040-080: standard 710 mm diameter fan

It is advisable to make the connection to the duct system with a flexible collar. If this recommendation is not observed, a lot of vibration and noise may be transmitted to the building structure.

The unit construction does not permit the support of a duct weighing more than 10 kg. Non-observance may lead to damage of the unit.

10.5.4 - Applicable regulations for units used with an air duct system

Ensure that the return or supply air openings cannot accidentally be obstructed by panels (for example low return air or opening of doors).

Unit performances are given for an air-side pressure drop that is indicated in the Physical Data table.

The three tables that follow contain fan characteristics, maximum air entering temperatures and performance correction factors, depending on the air system used with the units.

Fan data

30RY	Minimum available static pressure*		Nominal available static pressure		Maximum available static pressure	
	Pressure Pa	Flow l/s	Pressure Pa	Flow l/s	Pressure Pa	Flow l/s
017-026	0	2500	100	1940	150	1530
033	0	2920	100	2500	200	1940
040-050	0	4580	150	3890	230	3330
060	0	5560	150	4720	230	4030
070-080	0	6810	150	5830	230	5280

* Operation without duct system

Maximum air entering temperature, °C

30RY	At minimum air flow	At nominal air flow	At maximum air flow
017-026	44	46	47.5
033	44	46	47
040-050	44.5	46	47
060	44.5	46	47
070-080	44.5	46	47

Performance correction factors

30RY	Cooling capacity		Power input	
	Min. flow	Max. flow*	Min. flow	Max. flow*
017-026	0.98	1.01	1.03	0.97
033	0.98	1.005	1.03	0.98
040-050	0.985	1.005	1.02	0.98
060	0.985	1.005	1.02	0.98
070-080	0.985	1.005	1.01	0.98

* Operation without duct system

Correction factor for the published performances, given at nominal air flow

Accessory suction filter pressure drop

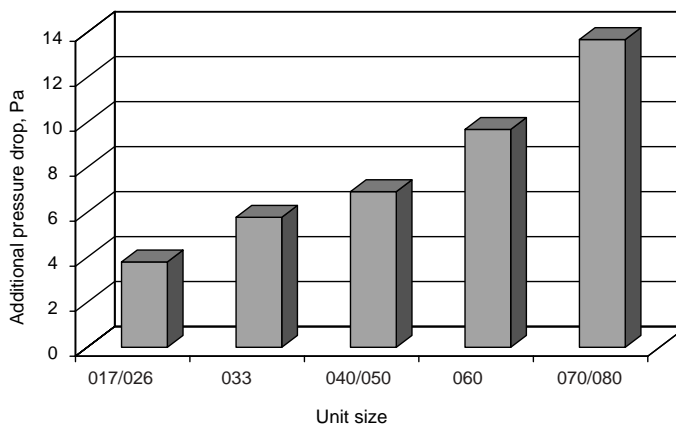

11 - START-UP

11.1 - Preliminary checks

- Never be tempted to start the chiller without reading fully, and understanding, the operating instructions and without having carried out the following pre-start checks:
- Check the chilled water circulation pumps, air handling units and all other equipment connected to the evaporator.
- Refer to the manufacturer's instructions.
- For units without hydronic module, the water pump overheat protection device must be connected in series with the pump contactor power supply. If the pump is not supplied with the unit (unit without hydronic module), verify that the power input of the field-installed pump does not exceed the rating of the standard pump contactor, supplied in the control box (max. 3 kW).
- Refer to the wiring diagram supplied with the unit.
- Ensure that there are no refrigerant leaks.
- Confirm that all pipe securing bands are tight.
- Confirm the the electrical connections are secure.

11.2 - Actual start-up

IMPORTANT

- *Commissioning and start-up of the chiller must be supervised by a qualified refrigeration engineer.*
- *It is strictly forbidden to energise the units, if the fan has not been connected to a duct system.*

The outdoor installation option includes a protection grille that does not require this connection.

- *Start-up and operating tests must be carried out with a thermal load applied and water circulating in the evaporator.*
- *All set-point adjustments and control tests must be carried out before the unit is started up.*
- *Please refer to the Controls manual for these units.*

The unit should be started up in Local ON mode.

Ensure that all safety devices are satisfied, especially the high pressure switches.

11.3 - Operation of two units in master/slave mode

The control of a master/slave assembly is in the entering water and does not require any additional sensors (standard configuration).

All parameters, required for the master/slave function must be configured using the Service Configuration menu. All remote controls of the master/slave assembly (start/stop, set point, load shedding etc.) are controlled by the unit configured as master and must only be applied to the master unit.

Depending on the installation and control type, each unit can control its own water pump. If there is only one common pump for the two units, the master unit can control this. In this case shut-off valves must be installed on each unit. They will be activated at the opening and closing by the control of each unit (and the valves will be controlled using the dedicated water pump outputs).

30RY 017 to 080 (standard configuration: return water control)

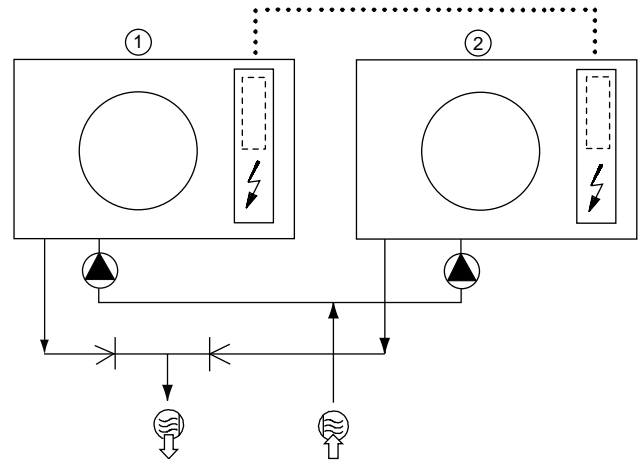

30RY 017 to 080 (with configuration: leaving water control)

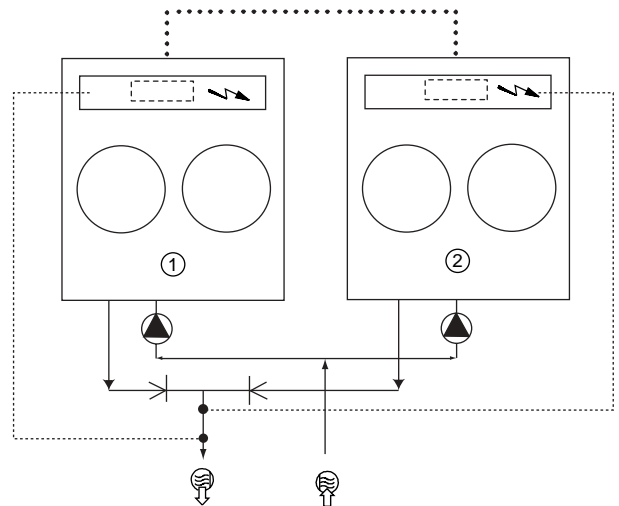

Legend

- 1 Master unit
- 2 Slave unit
- Additional CCN board (one per unit, with connection via communication bus)
- ⚡ Control boxes of the master and slave units
- ⊕ Water inlet
- ⊖ Water outlet
- ⚙ Water pumps for each unit (included as standard for units with hydronic module)
- Additional sensors for leaving water control, to be connected to channel 1 of the slave boards of each master and slave unit
- ... CCN communication bus
- Connection of two additional sensors

12 - MAINTENANCE

Any technician attending the machine for any purpose must be fully qualified to work on refrigerant and electrical circuits.

All refrigerant charging, removal and draining operations must be carried out by a qualified technician and with the correct material for the unit. Any inappropriate handling can lead to uncontrolled fluid or pressure leaks.

WARNING: Before doing any work on the machine ensure that the power is switched off. If a refrigerant circuit is opened, it must be evacuated, recharged and tested for leaks. Before any operation on a refrigerant circuit, it is necessary to remove the complete refrigerant charge from the unit with a refrigerant charge recovery group.

12.1 - General maintenance of the refrigerant circuit

- Keep the unit itself and the space around it clean and free of obstructions. Remove all rubbish such as packing materials, as soon as the installation is completed.
- Regularly clean the exposed pipework to remove all dust and dirt. This makes detection of water leaks easier, and they can be repaired before more serious faults develop.
- Confirm that all screwed and bolted connections and joints are secure. Secure connections prevent leaks and vibration from developing.
- Check that all insulation joints are securely closed and that all insulation is firmly in place. Check all heat exchangers and all pipework.

If water jets are used inside the units (e.g. to clean the coils), the lower holes (for possible condensate removal) must be blocked.

12.2 - Verification of the refrigerant charge

CAUTION: The 30RY units are supplied with a precise refrigerant charge (see Physical Data table).

To verify the correct system charge proceed as follows:
Ensure that no bubbles appear in the sight-glass, when operating the unit at full load for a while, at a saturated condensing temperature of between 55 and 57°C. If necessary cover a section of the coil surface to obtain this condensing temperature. Under these conditions the apparent subcooling which is equal to the saturated condensing temperature (1 - on the saturated dew point curve) minus the liquid refrigerant temperature (3) ahead of the expansion device must be between 12 and 14°C. This corresponds to an actual subcooling temperature of between 5 and 7 K at the condenser outlet, depending on the unit type. Actual subcooling is equal the saturated liquid temperature (2 - on the saturated bubble point curve) minus the liquid refrigerant temperature (3) ahead of the expansion device. Use the pressure tap supplied on the liquid piping to charge refrigerant and to find out the pressure of the liquid refrigerant. If the subcooling value is not correct, i.e. lower than the specified values, a leak detection test must be carried out on the unit, as it no longer contains its original charge.

In order to measure the liquid refrigerant pressure and temperature ahead of the expansion device, an access port must be opened on the expansion device which causes a slight air bypass on the condenser. Wait until unit operation has stabilized before carrying out pressure and temperature measurements.

WARNING: To ensure proper operation of 30RY units there must be at least 12 K of subcooling as the liquid refrigerant enters the expansion valve.

The 30RY units use refrigerant. For your information, we are reproducing here some extracts from the official publication dealing with the design, installation, operation and maintenance of air conditioning and refrigeration systems and the training of people involved in these activities, agreed by the air conditioning and refrigeration industry.

12.3 - Apparent and actual subcooling

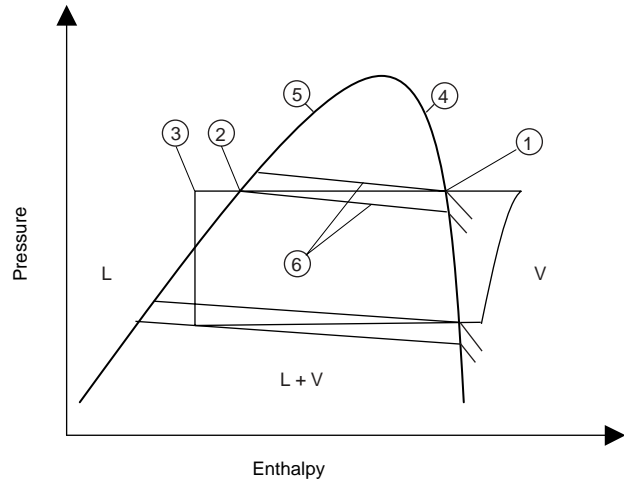

Legend

- 1 Saturated condensing temperature at the dew point
- 2 Saturated liquid temperature at the bubble point
- 3 Liquid refrigerant temperature
- 4 Saturation curve at the dew point
- 5 Saturation curve at the bubble point
- 6 Isotherms
- 7 Apparent subcooling (1 - 3)
- 8 Real subcooling (2 - 3)
- L Liquid
- L + V Liquid + vapour
- V Vapour